

ARYG12LLTB · ARYG14LLTB · ARYG18LLTB



ARYG12/14LLTB



ARYG18LLTB



Filocomando

Caratteristiche

Funzioni Comfort



Funzioni Timer



Sistema di controllo



Design sottile

Con soli 198 mm d'altezza questi modelli permettono un'installazione flessibile sia a soffitto che a pavimento.

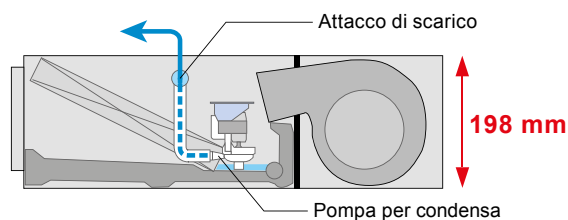

Pompa di scarico condensa come accessorio standard

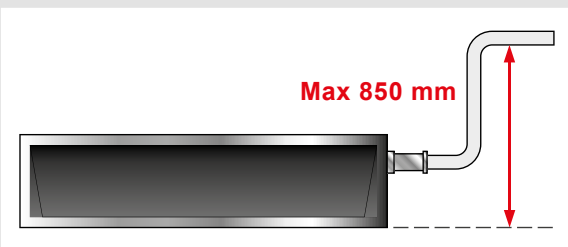

Kit gruppo alette (opzionale)

Eleganti alette autodirezionabili diffondono in modo uniforme l'aria all'interno del locale.

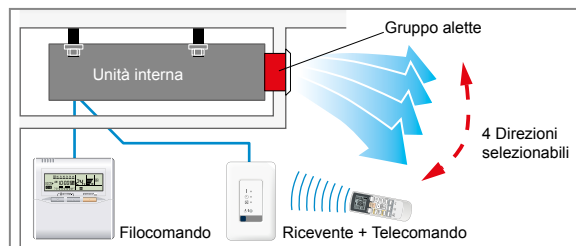

Ripresa dell'aria

La ripresa dell'aria può essere scelta in base alle esigenze d'installazione.

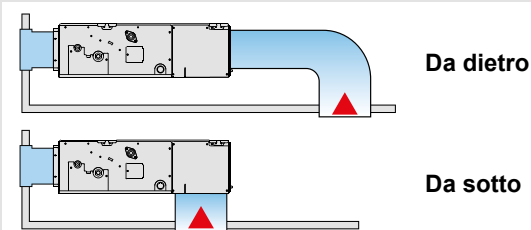

Accessori

Filocomando semplificato: UTY-RSNYM
Kit telecomando e ricevente: UTY-LRHYM

Sensore remoto: UTY-XSZX
Kit gruppo alette: UTD-GXSA-W (For ARYG12 / 14LLTB)
UTD-GXSB-W (For ARYG18LLTB)



Specifiche

			Modello	ARYG12LLTB	ARYG14LLTB	ARYG18LLTB
			Codice	3NGF8900	3NGF8905	3NGF8910
Alimentazione	V/Ø/Hz			230/1/50	230/1/50	230/1/50
Potenza	Raffrescamento	kW		3.5 (0.9-4.4)	4.3 (0.9-5.4)	5.2 (0.9-5.9)
	Riscaldamento	kW		4.1 (0.9-5.7)	5.0 (0.9-6.5)	6.0 (0.9-7.5)
Potenza assorbita	Raffrescamento/Riscaldamento	kW		1.05/1.11	1.33/1.34	1.62/1.66
EER	Raffrescamento			3.33	3.21	3.21
COP	Riscaldamento	W/W		3.69	3.71	3.61
Pdesign	Raffrescam./Riscaldam. (@-10°C)	kW		3.5/4.2	4.3/4.5	5.2/5.2
SEER	Raffrescamento			5.90	5.80	6.20
SCOP	Riscaldamento	W/W		4.00	3.90	4.10
Etichetta energetica	Raffrescamento			A+	A+	A++
	Riscaldamento			A+	A	A+
Corrente assorbita	Raffrescamento/Riscaldamento	A		4.8/5.1	6.1/6.1	7.2/7.4
Consumo energetico annuo	Raffrescamento	kWh/a		207	259	293
	Riscaldamento	kWh/a		1467	1614	1774
Capacità di deumidificazione		l/h		1.3	1.5	2.0
Pressione sonora (Raffrescamento)	Unità interna	A/M/B/S		29/28/26/25	32/30/28/26	32/30/29/27
	Unità esterna	Alta		47	49	50
Potenza sonora (Raffrescamento)	Unità interna	Alta		58	60	58
	Unità esterna	Alta		61	62	62
Portata d'aria (max.)	Unità interna/Unità esterna	m³/h		650/1780	800/1910	940/2000
Pressione statica (standard)		Pa		0 a 90 (25)	0 a 90 (25)	0 a 90 (25)
Dimensioni AxLxP	Unità interna	mm		198x700x620	198x700x620	198x900x620
		kg(lbs)		19 (42)	19 (42)	23 (51)
	Unità esterna	mm		578x790x300	578x790x300	578x790x300
		kg(lbs)		40 (88)	40 (88)	40 (88)
Attacchi tubazioni		mm		6.35/9.52	6.35/12.70	6.35/12.70
Diametro scarico condensa (int./est.)		mm		25/32	25/32	25/32
Massima lunghezza tubazioni (Precarica)		m		25 (15)	25 (15)	25 (15)
Massimo dislivello				15	15	15
Campo di funzionamento	Raffrescamento	°CDB		-10 a 46	-10 a 46	-10 a 46
	Riscaldamento	°CDB		-15 a 24	-15 a 24	-15 a 24
Refrigerante (GWP)				R410A (1,975)	R410A (1,975)	R410A (1,975)

Dimensioni (mm)

Modelli:
 ARYG12LLTB
 ARYG14LLTB
 ARYG18LLTB

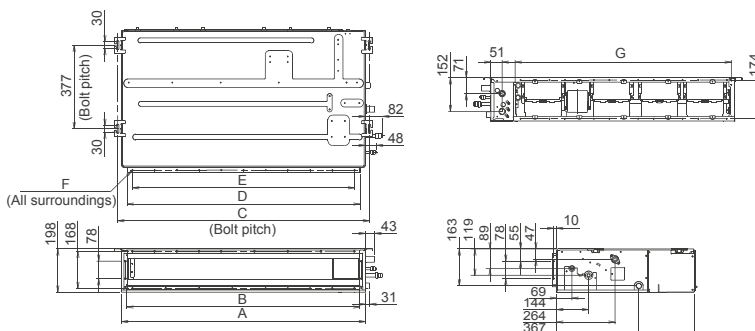

	ARYG12 / 14LLTB	ARYG18LLTB
A	700	900
B	650	850
C	734	934
D	650	850
E	P100x6=600	P100x8=800
F	18xØ5	22xØ5
G	574	774